



**BERLI**<sup>®</sup>  
MACCHINE AGRICOLE

**TA/MI  
TA/M  
TA  
TA/S  
TA/P  
TA/PS  
TA/PF  
WING**



**Trinciargini per trattori da 50 a 200 HP**



**In-line and offset mulchers for tractors from 50 to 200 HP**



**Böschungsmulcher für Traktoren von 50 bis 200 PS**



**Broyeurs multifonctions pour tracteurs de 50 a 200 CV**



**Trituradoras de laderas para tractores de 50 a 200 CV**





L'esperienza di oltre 50 anni nel settore delle macchine agricole permette alla ditta Berti di offrire alla sua vasta clientela una gamma completa di attrezzature tecnologicamente avanzate al servizio di un'agricoltura sempre più esigente e specializzata. La qualità dei prodotti fin dalla materia prima, la volontà di soddisfare sempre e prima di tutto le esigenze della clientela, la robustezza, l'affidabilità, hanno dato vita al largo consenso che queste macchine hanno ricevuto in tutto il mondo.



The experience of over 50 years in the manufacturing of farm implements makes it possible for Berti Company to offer a complete range of technologically advanced implements, to serve a more and more demanding and specialized agriculture.

The high quality, the sturdiness and the reliability of the products, the will to satisfy always the customer's requirement are the reasons of the large success enjoyed by these implements worldwide.





Die Firma Berti ha über 50 Jahre Erfahrung auf dem Gebiet der Landwirtschaftsmaschinen und ist also imstande, ihren zahlreichen Kunden eine komplette Palette von technologisch fortgeschrittenen Landwirtschaftsausrüstungen zu Verfügung zu stellen.

Die Produktqualität, gekennzeichnet durch die Wahl von Rohstoffen erster Klasse, die Beständigkeit und die Zuverlässigkeit der Maschinen, hat die Firma in die Lage gesetzt, diese in der ganzen Welt einzusetzen.

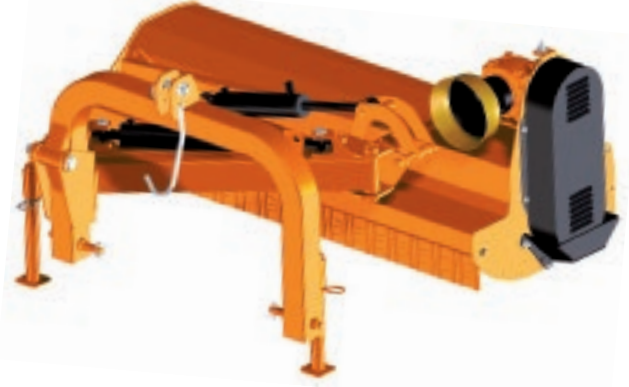

L'expérience acquise au cours de plus de 50 ans dans le monde de la machine agricole permet à la firme Berti d'offrir à ses nombreux clients une gamme complète d'équipements technologiquement à l'avant-garde au service d'une agriculture exigeante et professionnelle. La qualité des produits à partir de la matière première, la volonté de satisfaire surtout les exigences de la clientèle, la résistance et la fiabilité ont permis à nos machines d'obtenir un accueil très favorable dans le monde entier.



La experiencia de más de 50 años en el sector de las máquinas agrícolas ha permitido a la empresa Berti ofrecer a sus clientes una gama completa de equipos tecnológicamente avanzados para una agricultura cada vez más especializada. Gracias a la robustez y a la fiabilidad de los productos y a una calidad que se busca incluso en las materias primas empleadas, unido a la voluntad de satisfacer siempre y en primer lugar las exigencia de los clientes, Berti se ha hecho famosa en todo el mundo.

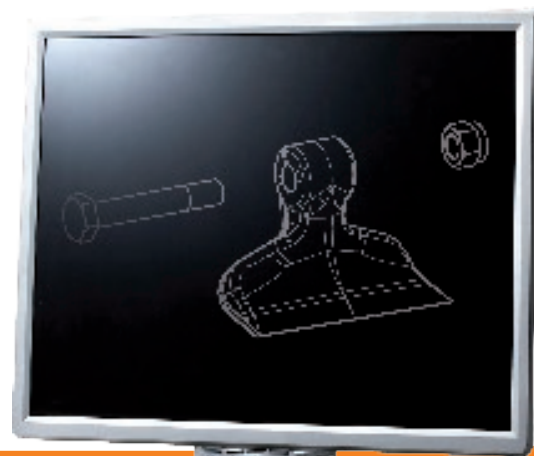



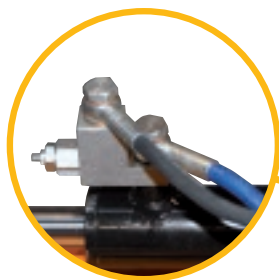

- Valvola di sicurezza.
- Safety valve.
- Sicherheitsventil.
- Soupape de sûreté.
- Válvula de seguridad.



- Valvola di blocco.
- Block valve.
- Sperrventilblock.
- Soupape de bloc.
- Válvula de bloque.

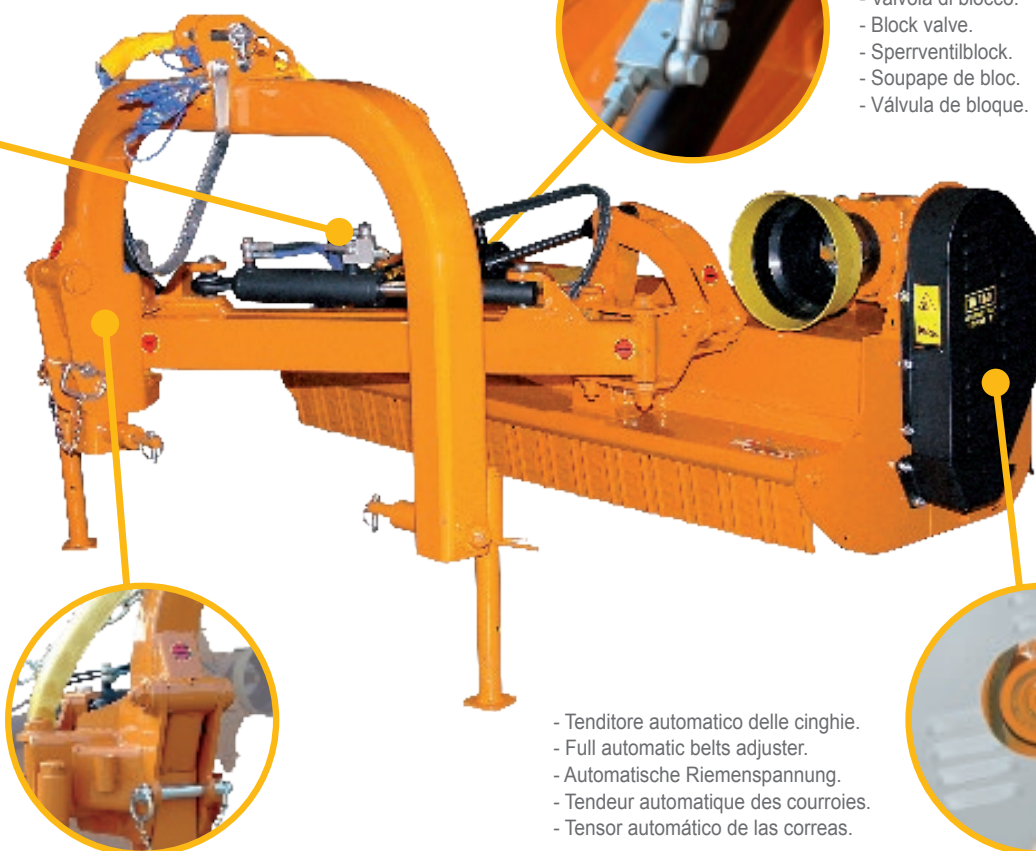



- Attacco terzo punto con sistema flottante e fermo di sicurezza.
- 3 point linkage with floating system and safety lock.
- Dreipunktbock mit Schwimmstellung-System und Sperrbolzen.
- Attelage à 3 points avec système flottante et arrêt de sécurité.
- Enganche a los tres puntos con sistema flotante y bloqueo de seguridad.





- Tenditore automatico delle cinghie.
- Full automatic belts adjuster.
- Automatische Riemenspannung.
- Tendeur automatique des courroies.
- Tensor automático de las correas.



 Trinciatrice compatta multiuso con attacco ai tre punti Cat. II (**Cat. I a richiesta**), da applicare a trattori con potenza compresa tra 50 e 90 HP. Adatta a lavorare sia posteriormente che lateralmente al trattore. E' consigliata per erba, residui vegetali, cespugli e sarmenti di  $\varnothing$  3-4 cm.. Ideale per la pulizia di parchi, aree verdi, giardini, bordi di strade, su fossati, argini e terreni inclinati in genere.







 Broyeur d'accotement multifonctions avec attelage à 3 points Cat. II (**Cat. I sur demande**) pour broyer l'herbe, les déchets végétaux, les buissons et les sarments allant jusqu'à  $\varnothing$  3-4 cm; indiqué pour tracteurs de 50 à 90 CV. Il est idéal pour le nettoyage des espaces verts, des jardins, des rebords de route, des fossés, des digues et des terrains inclinés.

 Offset/in-line mulcher for grass, residue of vegetables, bushes and pruning up to  $\varnothing$  3-4 cm., with 3-point linkage Cat. II (**Cat. I on request**). Suited for tractors from 50 to 90 HP and ideal for clearing green areas, gardens, slopes, ditches, banks of watercourses, road side banks.

 Desbrozadora indicada con enganche a los 3 puntos Cat. II (**Cat. I bajo petición**) para la trituración de hierba, residuos vegetales, arbustos y restos de poda (hasta 3-4 cm  $\varnothing$ ), para tractores de 50 a 90 C.V. Ideal para parques, áreas verdes, jardines, cunetas y terrenos en pendiente en general.

 Universalgerät für Heckanbau, für seitliches Mulchen oder hinter dem Schlepper mit Dreipunktbock Kat.II (**Kat. I auf Anfrage**); für Gras, Vegetation, Reisig und Äste bis  $\varnothing$  3-4 cm, für Randstreifen, Wassergräben und Böschungen, für Traktoren von 50 bis 90 PS.

*Il trattore deve essere dotato di almeno n.2 prese d'olio a doppio effetto / The tractor has to be equipped with n. 2 double effect oil plugs / Der Traktor muss mit 2 doppelwirkenden Hydraulikanschlüssen ausgestattet sein / Le tracteur doit être équipé avec au moins 2 prises d'huile à double effet / El tractor deberá estar equipado con al menos dos enchufes hidráulicos con válvula de doble efecto.*

Mod.													
	cm	Min	Max	n°	n°	n°	PTO	A	B	C	D	E	ca.(*)
<b>TA/MI 145</b>	145	50	90	14	42	3	540	145	170	59	210	130	545
<b>TA/MI 160</b>	160	50	90	14	42	3	540	160	170	59	225	145	570
<b>TA/MI 180</b>	180	50	90	16	48	3	540	180	170	59	245	165	600
<b>TA/MI 200</b>	200	50	90	18	54	3	540	200	170	59	265	185	630

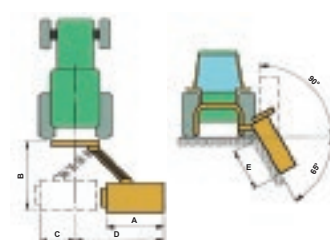

\* Il peso è riferito alla macchina standard (senza accessori) • The weight refers to the machine with standard equipment (without accessories) • Die Gewichtsangabe bezieht sich auf die Maschine in Grundausstattung (ohne Sonderausstattung) • Le poids se réfère à la machine standard (sans accessoires) • El peso se refiere al estándar de la máquina (sin accesorios).



- Sistema flottante con limitatore.
- Floating device, with limiter.
- Schwimmstellung-System mit Hubbegrenzer.
- Système flottante avec limiteur.
- Sistema de engancho flotante con limitador.



- Rullo livellatore posteriore autopulente, regolabile in altezza.
- Height adjustable self-cleaning levelling roller.
- Höhenverstellbare und selbstreinigende Stützwalze.
- Rouleau palpeur autonettoyant, réglable en hauteur.
- Rodillo trasero autolimpiable y regulable en altura.

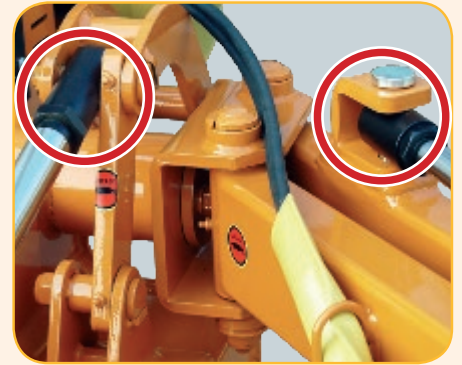

- Martinetti regolabili.
- Adjustable cylinders.
- Einstellbare hydr. Zylindern.
- Vêrins réglables.
- Cilindros hidráulicos con extensión ajustable.



- Fiancata destra arrotondata.
- Chamfered profile on the right-end chassis corner.
- Seitlich Abschrägung auf Mulcherrahmen.
- Coin côté droite arrondi.
- Perfil rebajado en la parte derecha.



- Albero cardanico rinforzato.
- Hardened PTO drive shaft.
- Verstärkte Gelenkwelle.
- Cardan à profil renforcé.
- Eje de TDF reforzado.

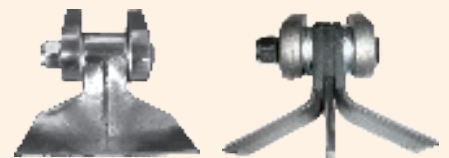

Optional

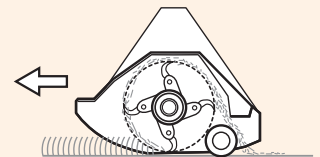

## OPTIONALS



- Sistema antishock BERTI\*.
- Exclusive BERTI Anti-Shock Device\*.
- Anti-Schock System BERTI\*.
- Système antichoc exclusif BERTI\*.
- Dispositivo antichoque exclusivo de Berti\*.



- Slitte d'appoggio antiusura.
- Skids of anti-wearing steel.
- Satz Kufen mit Anti-Verschleißmaterial.
- Jeu patins anti-usure.
- Patines de acero reforzado anti-desgaste.



- Albero cardanico doppio omocinetico.
- Double Wide-Angle drive shaft.
- Doppel-Weitwinkel Gelenkwelle.
- Cardan double homocinétique.
- Cardan doble homocinético.



# TA/M

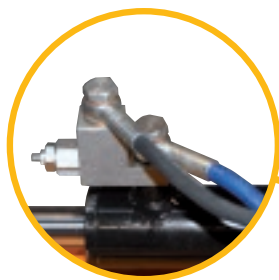

- Valvola di sicurezza.
- Safety valve.
- Sicherheitsventil.
- Soupape de sûreté.
- Válvula de seguridad.



- Valvola di blocco.
- Block valve.
- Sperrventilblock.
- Soupape de bloc.
- Válvula de bloque.



- Attacco terzo punto con sistema flottante e fermo di sicurezza.
- 3 point linkage with floating system and safety lock.
- Dreipunktbock mit Schwimmstellung-System und Sperrbolzen.
- Attelage à 3 points avec système flottante et arrêt de sécurité.
- Enganche a los tres puntos con sistema flotante y bloqueo de seguridad.

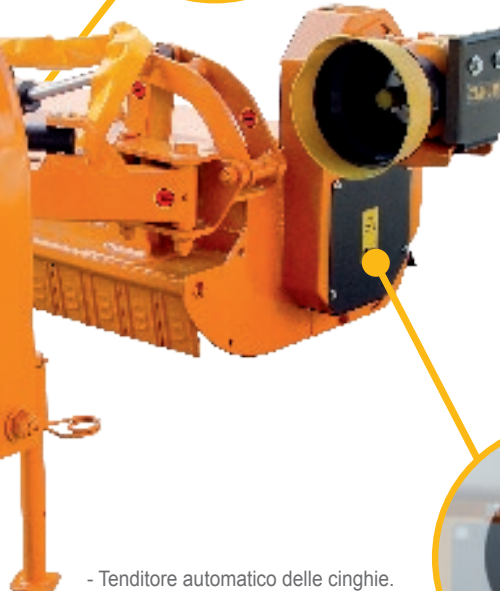

- Tenditore automatico delle cinghie.
- Full automatic belts adjuster.
- Automatische Riemenspannung.
- Tendeur automatique des courroies.
- Tensor automático de las correas.

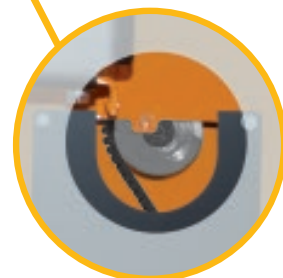

Trinciatrice compatta multiuso con attacco ai tre punti Cat. II (**Cat. I a richiesta**), da applicare a trattori con potenza compresa tra 50 e 90 HP. Adatta a lavorare sia posteriormente che lateralmente al trattore. E' consigliata per erba, residui vegetali, cespugli e sarmenti di  $\varnothing$  3-4 cm.. Ideale per la pulizia di parchi, aree verdi, giardini, bordi di strade, su fossati, argini e terreni inclinati in genere.



Broyeur d'accotement multifonctions avec attelage à 3 points Cat. II (**Cat. I sur demande**) pour broyer l'herbe, les déchets végétaux, les buissons et les sarments allant jusqu'à  $\varnothing$  3-4 cm; indiqué pour tracteurs de 50 à 90 CV. Il est idéal pour le nettoyage des espaces verts, des jardins, des rebords de route, des fossés, des digues et des terrains inclinés.



Offset/in-line mulcher for grass, residue of vegetables, bushes and pruning up to  $\varnothing$  3-4 cm., with 3-point linkage Cat. II (**Cat. I on request**). Suited for tractors from 50 to 90 HP and ideal for clearing green areas, gardens, slopes, ditches, banks of watercourses, road side banks.



Desbrozadora indicada con enganche a los 3 puntos Cat. II (**Cat. I bajo petición**) para la trituración de hierba, residuos vegetales, arbustos y restos de poda (hasta 3-4 cm  $\varnothing$ ), para tractores de 50 a 90 C.V. Ideal para parques, áreas verdes, jardines, cunetas y terrenos en pendiente en general.



Universalgerät für Heckanbau, für seitliches Mulchen oder hinter dem Schlepper mit Dreipunktbock Kat.II (**Kat. I auf Anfrage**); für Gras, Vegetation, Reisig und Äste bis  $\varnothing$  3-4 cm, für Randstreifen, Wassergräben und Böschungen, für Traktoren von 50 bis 90 PS.

*Il trattore deve essere dotato di almeno n.2 prese d'olio a doppio effetto / The tractor has to be equipped with n. 2 double effect oil plugs / Der Traktor muss mit 2 doppelwirkenden Hydraulikanschlüssen ausgestattet sein / Le tracteur doit être équipé avec au moins 2 prises d'huile à double effet / El tractor deberá estar equipado con al menos dos enchufes hidráulicos con válvula de doble efecto.*

Mod.														
		HP	HP					A	B	C	D	E		ca. (*)
	cm	Min	Max	n°	n°	n°	PTO	cm	cm	cm	cm	cm	cm	Kg
<b>TA/M 145</b>	145	50	90	14	42	3	540	145	170	20	248	130	560	
<b>TA/M 160</b>	160	50	90	14	42	3	540	160	170	20	263	145	580	
<b>TA/M 180</b>	180	50	90	16	48	3	540	180	170	20	283	165	620	
<b>TA/M 200</b>	200	50	90	18	54	3	540	200	170	20	303	185	660	

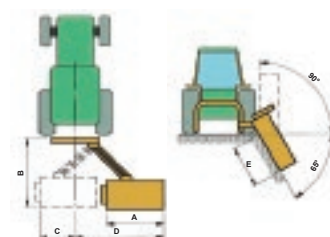

\* Il peso è riferito alla macchina standard (senza accessori) • The weight refers to the machine with standard equipment (without accessories) • Die Gewichtsangabe bezieht sich auf die Maschine in Grundausstattung (ohne Sonderausstattung) • Le poids se réfère à la machine standard (sans accessoires) • El peso se refiere al estándar de la máquina (sin accesorios).



- Sistema flottante con limitatore.
- Floating device, with limiter.
- Schwimmstellung-System mit Hubbegrenzer.
- Système flottante avec limiteur.
- Sistema de engancho flotante con limitador.



- Rullo livellatore posteriore autopulente, regolabile in altezza.
- Height adjustable self-cleaning levelling roller.
- Höhenverstellbare und selbstreinigende Stützwalze.
- Rouleau palpeur autonettoyant, réglable en hauteur.
- Rodillo trasero autolimpiable y regulable en altura.

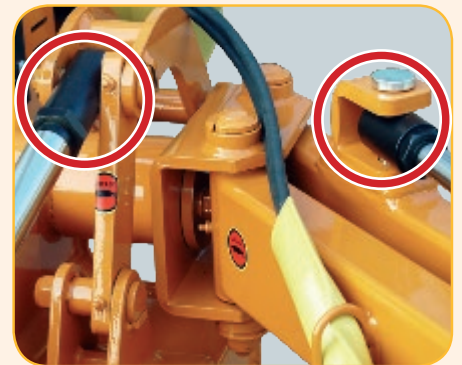

- Martinetti regolabili.
- Adjustable cylinders.
- Einstellbare hydr. Zylindern.
- Vêrins réglables.
- Cilindros hidráulicos con extensión ajustable.



- Fiancata destra arrotondata.
- Chamfered profile on the right-end chassis corner.
- Seitlich Abschrägung auf Mulcherrahmen.
- Coin côté droite arrondi.
- Perfil rebajado en la parte derecha.



- Albero cardanico rinforzato.
- Hardened PTO drive shaft.
- Verstärkte Gelenkwelle.
- Cardan à profil renforcé.
- Eje de TDF reforzado.

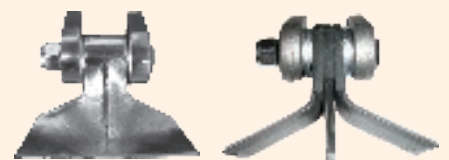

Optional

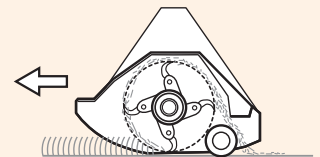

## OPTIONALS



- Sistema antishock BERTI\*.
- Exclusive BERTI Anti-Shock Device\*.
- Anti-Schock System BERTI\*.
- Système antichoc exclusif BERTI\*.
- Dispositivo antichoque exclusivo de Berti\*.



- Slitte d'appoggio antiusura.
- Skids of anti-wearing steel.
- Satz Kufen mit Anti-Verschleißmaterial.
- Jeu patins anti-usure.
- Patines de acero reforzado anti-desgaste.



- Albero cardanico doppio omocinetico.
- Double Wide-Angle drive shaft.
- Doppel-Weitwinkel Gelenkwelle.
- Cardan double homocinétique.
- Cardan doble homocinético.



# TA



- Valvola di sicurezza.
- Safety valve.
- Sicherheitsventil.
- Soupape de sûreté.
- Válvula de seguridad.



- Valvola di blocco.
- Block valve.
- Sperrventilblock.
- Soupape de bloc.
- Válvula de bloque.



- Attacco terzo punto con sistema flottante e fermo di sicurezza.
- 3 point linkage with floating system and safety lock.
- Dreipunktbock mit Schwimmstellung-System und Sperrbolzen.
- Attelage à 3 points avec système flottante et arrêt de sécurité.
- Enganche a los tres puntos con sistema flotante y bloqueo de seguridad.



- Tenditore automatico delle cinghie.
- Full automatic belts adjuster.
- Automatische Riemenspannung.
- Tendeur automatique des courroies.
- Tensor automático de las correas.



Trinciatrice compatta multiuso, da applicare a trattori con potenza compresa tra 60 e 110 HP. Adatta a lavorare sia posteriormente che lateralmente al trattore. E' consigliata per erba, residui vegetali, ceppugli e sarmenti di  $\varnothing$  5-6 cm.. Ideale per la pulizia di parchi, aree verdi, giardini, bordi di strade, su fossati, argini e terreni inclinati in genere.



Broyeur d'accotement multifonctions pour broyer l'herbe, les déchets végétaux, les buissons et les sarments allant jusqu'à  $\varnothing$  5-6 cm; indiqué pour tracteurs de 60 à 110 CV. Il est idéal pour le nettoyage des espaces verts, des jardins, des rebords de route, des fossés, des digues et des terrains inclinés.



Offset/in-line mulcher for grass, residue of vegetables, bushes and pruning up to  $\varnothing$  5-6 cm., suited for tractors from 60 to 110 HP. Ideal for clearing green areas, gardens, slopes, ditches, banks of water-courses, road side banks.



Desbrozadora indicada para la trituración de hierba, residuos vegetales, arbustos y restos de poda (hasta 5-6 cm  $\varnothing$ ), para tractores de 60 a 110 C.V. Ideal para par-ques, áreas verdes, jardines, cunetas y terrenos en pendiente en general.



Universalgerät für Heckanbau, für seitliches Mulchen oder hinter dem Schlepper für Gras, Vegetation, Reisig und Äste bis  $\varnothing$  5-6 cm für Randstreifen, für Wassergräben und Böschungen, für Traktoren von 60 bis 110 PS.

*Il trattore deve essere dotato di almeno n.2 prese d'olio a doppio effetto / The tractor has to be equipped with n. 2 double effect oil plugs / Der Traktor muss mit 2 doppelwirkenden Hydraulikanschlüssen ausgestattet sein / Le tracteur doit être équipé avec au moins 2 prises d'huile à double effet / El tractor deberá estar equipado con al menos dos enchufes hidráulicos con válvula de doble efecto.*

Mod.													
							HP	A	B	C	D		E
	cm	Min	Max	n°	n°	n°	PTO	cm	cm	cm	cm	cm	Kg
<b>TA 160</b>	160	60	110	14	42	4	540	160	170	60	230	145	755
<b>TA 180</b>	180	60	110	16	48	4	540	180	170	60	250	165	790
<b>TA 200</b>	200	60	110	18	54	4	540	200	170	60	270	185	830
<b>TA 220</b>	220	60	110	20	60	4	540	220	170	60	290	205	865
<b>TA 250</b>	250	60	110	22	66	4	540	250	170	60	320	235	950

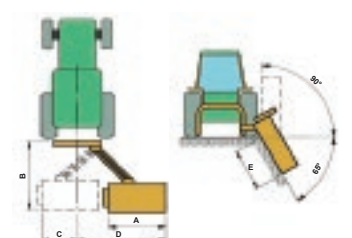

\* Il peso è riferito alla macchina standard (senza accessori) • The weight refers to the machine with standard equipment (without accessories) • Die Gewichtsangabe bezieht sich auf die Maschine in Grundausstattung (ohne Sonderausstattung) • Le poids se réfère à la machine standard (sans accessoires) • El peso se refiere al estándar de la máquina (sin accesorios).





- Sistema flottante con limitatore.
- Floating device, with limiter.
- Schwimmstellung-System mit Hubbegrenzer.
- Système flottante avec limiteur.
- Sistema de enganche flotante con limitador.



- Rullo autopulente regolabile in altezza.
- Self-cleaning and height adjustable roller.
- Selbstreinigender und höhenverstellbarer Stützwalze.
- Rouleau auto-nettoyant réglable en hauteur.
- Rodillo auto-limpiable regulable en altura.

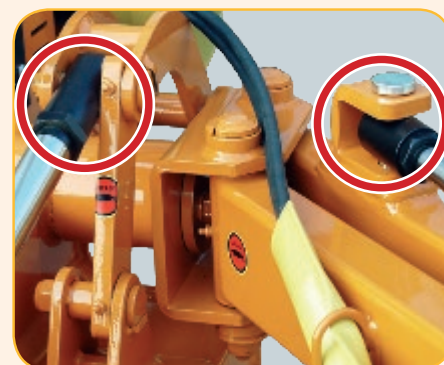

- Martinetti regolabili.
- Adjustable cylinders.
- Einstellbare hydr. Zylindern.
- Vérins réglables.
- Cilindros hidráulicos con extensión ajustable.



- Fiancata destra arrotondata.
- Chamfered profile on the right-end chassis corner.
- Seitlich Abschrägung auf Mulcherrahmen.
- Coin côté droite arrondi.
- Perfil rebajado en la parte derecha.



- Albero cardanico rinforzato.
- Hardened PTO drive shaft.
- Verstärkte Gelenkwelle.
- Cardan à profil renforcé.
- Eje de TDF reforzado.



Optional

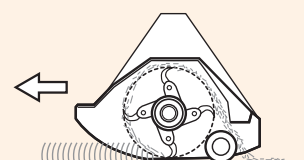

## OPTIONALS



- Sistema antishock BERTI\*.
- Exclusive BERTI Anti-Shock Device\*.
- Anti-Schock System BERTI\*.
- Système antichoc exclusif BERTI\*.
- Dispositivo antichoque exclusivo de Berti\*.



- Slitte d'appoggio antiusura.
- Skids of anti-wearing steel.
- Satz Kufen mit Anti-Verschleißmaterial.
- Jeu patins anti-usure.
- Patines de acero reforzado anti-desgaste.



- Albero cardanico doppio omocinetico.
- Double Wide-Angle drive shaft.
- Doppel-Weitwinkel Gelenkwelle.
- Cardan double homocinétique.
- Cardan doble homocinético.

# TA/S





- Valvola di sicurezza.
- Safety valve.
- Sicherheitsventil.
- Soupape de sûreté.
- Válvula de seguridad.

- Valvola di blocco.
- Block valve.
- Sperrventilblock.
- Soupape de bloc.
- Válvula de bloque.

- Attacco terzo punto con sistema flottante e fermo di sicurezza.
- 3 point linkage with floating system and safety lock.
- Dreipunktbock mit Schwimmstellung-System und Sperrbolzen.
- Attelage à 3 points avec système flottante et arrêt de sécurité.
- Enganche a los tres puntos con sistema flotante y bloqueo de seguridad.

- Tenditore automatico delle cinghie.
- Full automatic belts adjuster.
- Automatische Riemenspannung.
- Tendeur automatique des courroies.
- Tensor automático de las correas.

 Trinciatrice compatta multiuso, da applicare a trattori con potenza compresa tra 60 e 110 HP. Adatta a lavorare sia posteriormente che lateralmente al trattore. E' consigliata per erba, residui vegetali, cespugli e sarmenti di  $\varnothing$  5-6 cm.. Ideale per la pulizia di parchi, aree verdi, giardini, bordi di strade, su fossati, argini e terreni inclinati in genere.







 Broyeur d'acotement multifonctions pour broyer l'herbe, les déchets végétaux, les buissons et les tiges allant jusqu'à  $\varnothing$  5-6 cm; adapté pour tracteurs de 60 à 110 CV. Il est idéal pour le nettoyage des espaces verts, des jardins, des rebords de route, des fossés, des digues et des terrains inclinés.

 Offset/in-line mulcher for grass, residue of vegetables, bushes and pruning up to  $\varnothing$  5-6 cm., suited for tractors from 60 to 110 HP. Ideal for clearing green areas, gardens, slopes, ditches, banks of water-courses, road side banks.

 Desbrozadora indicada para la trituración de hierba, residuos vegetales, arbustos y restos de poda (hasta 5-6 cm  $\varnothing$ ), para tractores de 60 a 110 C.V. Ideal para parques, áreas verdes, jardines, cunetas y terrenos en pendiente en general.

 Universalgerät für Heckanbau, für seitliches Mulcher oder hinter dem Schlepper für Gras, Vegetation, Reisig und Äste bis  $\varnothing$  5-6 cm. für Randstreifen, für Wassergräben und für Böschungen, für Traktoren von 60 bis 110 PS.

*Il trattore deve essere dotato di almeno n.2 prese d'olio a doppio effetto / The tractor has to be equipped with n. 2 double effect oil plugs / Der Traktor muss mit 2 doppelwirkenden Hydraulikanschlüssen ausgestattet sein / Le tracteur doit être équipé avec au moins 2 prises d'huile à double effet / El tractor deberá estar equipado con al menos dos enchufes hidráulicos con válvula de doble efecto.*

Mod.													
	cm	Min	Max	n°	n°	n°	PTO	A	B	C	D	E	Kg
<b>TA/S 140</b>	140	60	110	12	36	4	540	140	170	15	260	140	730
<b>TA/S 160</b>	160	60	110	14	42	4	540	160	170	15	275	160	775
<b>TA/S 180</b>	180	60	110	16	48	4	540	180	170	15	295	180	810
<b>TA/S 200</b>	200	60	110	18	54	4	540	200	170	15	315	200	850
<b>TA/S 220</b>	220	60	110	20	60	4	540	220	170	15	335	220	885

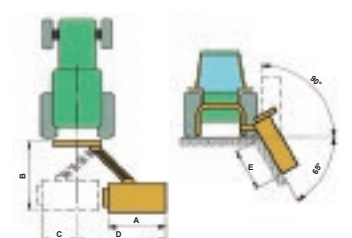

\* Il peso è riferito alla macchina standard (senza accessori) • The weight refers to the machine with standard equipment (without accessories) • Die Gewichtsangabe bezieht sich auf die Maschine in Grundausstattung (ohne Sonderausstattung) • Le poids se réfère à la machine standard (sans accessoires) • El peso se refiere al estándar de la máquina (sin accesorios).





- Sistema flottante con limitatore.
- Floating device, with limiter.
- Schwimmstellung-System mit Hubbegrenzer.
- Système flottante avec limiteur.
- Sistema de enganche flotante con limitador.



- Rullo autopulente regolabile in altezza.
- Self-cleaning and height adjustable roller.
- Selbstreinigender und höhenverstellbarer Stützwalze.
- Rouleau auto-nettoyant réglable en hauteur.
- Rodillo auto-limpiable regulable en altura.

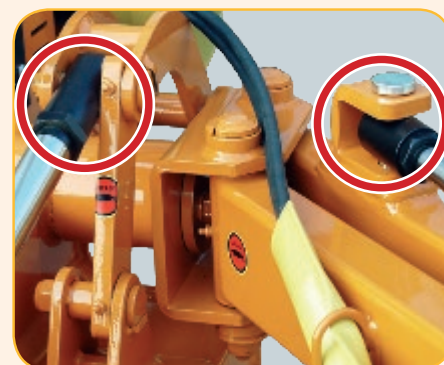

- Martinetti regolabili.
- Adjustable cylinders.
- Einstellbare hydr. Zylindern.
- Vérins réglables.
- Cilindros hidráulicos con extensión ajustable.



- Fiancata destra arrotondata.
- Chamfered profile on the right-end chassis corner.
- Seitlich Abschrägung auf Mulcherrahmen.
- Coin côté droite arrondi.
- Perfil rebajado en la parte derecha.



- Albero cardanico rinforzato.
- Hardened PTO drive shaft.
- Verstärkte Gelenkwelle.
- Cardan à profil renforcé.
- Eje de TDF reforzado.



Optional

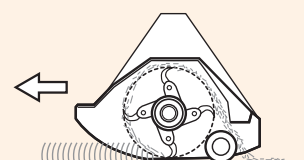

## OPTIONALS



- Sistema antishock BERTI\*.
- Exclusive BERTI Anti-Shock Device\*.
- Anti-Schock System BERTI\*.
- Système antichoc exclusif BERTI\*.
- Dispositivo antichoque exclusivo de Berti\*.



- Slitte d'appoggio antiusura.
- Skids of anti-wearing steel.
- Satz Kufen mit Anti-Verschleißmaterial.
- Jeu patins anti-usure.
- Patines de acero reforzado anti-desgaste.



- Albero cardanico doppio omocinetico.
- Double Wide-Angle drive shaft.
- Doppel-Weitwinkel Gelenkwelle.
- Cardan double homocinétique.
- Cardan doble homocinético.

# TA/P





- Valvola di sicurezza.
- Safety valve.
- Sicherheitsventil.
- Soupape de sûreté.
- Válvula de seguridad.

- Valvola di blocco.
- Block valve.
- Sperrventilblock.
- Soupape de bloc.
- Válvula de bloque.

- Attacco terzo punto con sistema flottante e fermo di sicurezza.
- 3 point linkage with floating system and safety lock.
- Dreipunktbock mit Schwimmstellung-System und Sperrbolzen.
- Attelage à 3 points avec système flottante et arrêt de sécurité.
- Enganche a los tres puntos con sistema flotante y bloqueo de seguridad.

- Tenditore automatico delle cinghie.
- Full automatic belts adjuster.
- Automatische Riemenspannung.
- Tendeur automatique des courroies.
- Tensor automático de las correas.

 Trinciatrice professionale multiuso da applicare a trattori con potenza compresa tra 80 e 180 HP. Adatta a lavorare sia posteriormente che lateralmente al trattore. E' consigliata per erba, residui vegetali, ceppugli e sarmenti fino a  $\varnothing$  7 cm., Ideale per la pulizia di parchi, aree verdi, giardini, bordi di strade, su fossati, argini e terreni inclinati in genere







 Broyeur professionnel renforcé multifonctions pour broyer l'herbe, les déchets végétaux, les buissons et les sarments allant de  $\varnothing$  7 cm; adapté pour tracteurs de 80 à 180 CV. Machine idéale pour les personnes qui travaillent pour le compte de tiers et qui doivent nettoyer le rebord des routes, fossés, digues et espaces verts publics.

 Heavy-duty offset / in-line mulcher for grass, residue of vegetables, bushes and pruning up to  $\varnothing$  7 cm., suited for tractors from 80 to 180 HP. Ideal machine for contractors who need to clear slopes, ditches, banks of watercourses, road side banks and public green areas in general.

 Desbrozadora de uso profesional indicada para la trituración de hierba, residuos vege-tales, arbustos y restos de poda (hasta 7 cm  $\varnothing$ ), para tractores de 80 a 180 C.V. Ideal para parques, áreas verdes, jardines, cune-tas y terrenos en pendiente en general.

 Universalgerät für Heckanbau, für seitliches Mulchen oder hinter dem Schlepper für Gras, Vegetation, Reisig und Äste mit  $\varnothing$  7 cm. für Randstreifen, für Wassergräben und für Böschungen für Traktoren von 80 bis 180 PS.

*Il trattore deve essere dotato di almeno n.2 prese d'olio a doppio effetto / The tractor has to be equipped with n. 2 double effect oil plugs / Der Traktor muss mit 2 doppelwirkenden Hydraulikanschlüssen ausgestattet sein / Le tracteur doit être équipé avec au moins 2 prises d'huile à double effet / El tractor deberá estar equipado con al menos dos enchufes hidráulicos con válvula de doble efecto.*

Mod.														
		HP	Min					Max	n°	n°	n°	PTO		A
	cm							cm	cm	cm	cm	cm	cm	
TA/P 160	160	80	180	14	42	5	540	160	180	60	235	130	880	
TA/P 180	180	85	180	16	48	5	540	180	180	60	255	150	980	
TA/P 200	200	85	180	18	54	5	540	200	180	60	275	170	1020	
TA/P 220	220	85	180	20	60	5	540	220	180	60	295	190	1070	
TA/P 250	250	100	180	22	66	5	540	250	180	60	325	220	1180	

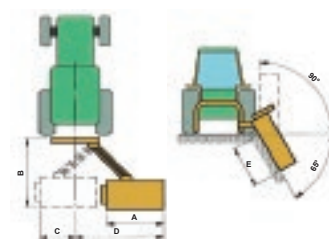

\* Il peso è riferito alla macchina standard (senza accessori) • The weight refers to the machine with standard equipment (without accessories) • Die Gewichtsangabe bezieht sich auf die Maschine in Grundausstattung (ohne Sonderausstattung) • Le poids se réfère à la machine standard (sans accessoires) • El peso se refiere al estándar de la máquina (sin accesorios).





- Sistema flottante con limitatore.
- Floating device, with limiter.
- Schwimmstellung-System mit Hubbegrenzer.
- Système flottante avec limiteur.
- Sistema de enganche flotante con limitador.



- Rullo autopulente regolabile in altezza.
- Self-cleaning and height adjustable roller.
- Selbstreinigender und höhenverstellbarer Stützwalze.
- Rouleau auto-nettoyant réglable en hauteur.
- Rodillo auto-limpiable regulable en altura.

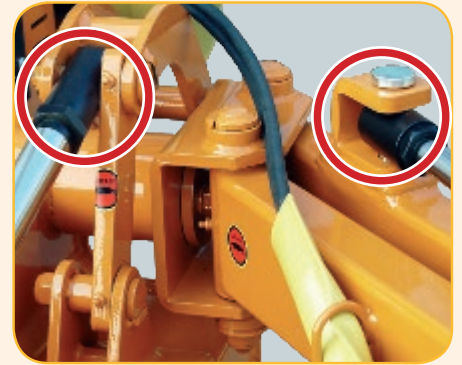

- Martinetti regolabili.
- Adjustable cylinders.
- Einstellbare hydr. Zylinder.
- Vérins réglables.
- Cilindros hidráulicos con extensión ajustable.

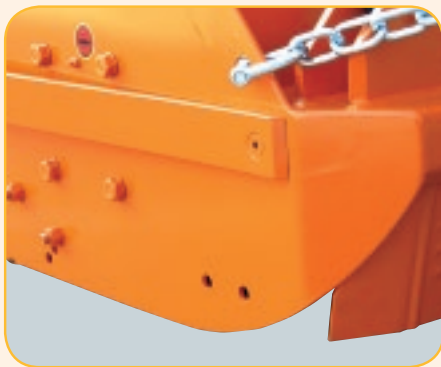

- Fiancata destra arrotondata.
- Chamfered profile on the right-end chassis corner.
- Seitlich Abschrägung auf Mulcherrahmen.
- Coin côté droite arrondi.
- Perfil rebajado en la parte derecha.



- Albero cardanico rinforzato.
- Hardened PTO drive shaft.
- Verstärkte Gelenkwelle.
- Cardan à profil renforcé.
- Eje de TDF reforzado.



Optional

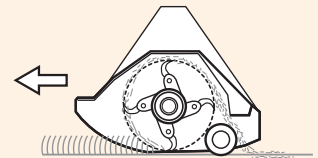

## OPTIONALS



- Sistema antishock BERTI\*.
- Exclusive BERTI Anti-Shock Device\*.
- Anti-Schock System BERTI\*.
- Système antichoc exclusif BERTI\*.
- Dispositivo antichoque exclusivo de Berti\*.



- Slitte d'appoggio antiusura.
- Skids of anti-wearing steel.
- Satz Kufen mit Anti-Verschleißmaterial.
- Jeu patins anti-usure.
- Patines de acero reforzado anti-desgaste.



- Albero cardanico doppio omocinetico.
- Double Wide-Angle drive shaft.
- Doppel-Weitwinkel Gelenkwelle.
- Cardan double homocinétique.
- Cardan doble homocinético.

# TA/PS



- Valvola di sicurezza.
- Safety valve.
- Sicherheitsventil.
- Soupape de sûreté.
- Válvula de seguridad.



- Valvola di blocco.
- Block valve.
- Sperrventilblock.
- Soupape de bloc.
- Válvula de bloque.



- Attacco terzo punto con sistema flottante e fermo di sicurezza.
- 3 point linkage with floating system and safety lock.
- Dreipunktbock mit Schwimmstellung-System und Sperrbolzen.
- Attelage à 3 points avec système flottante et arrêt de sécurité.
- Enganche a los tres puntos con sistema flotante y bloqueo de seguridad.



- Tenditore automatico delle cinghie.
- Full automatic belts adjuster.
- Automatische Riemenspannung.
- Tendeur automatique des courroies.
- Tensor automático de las correas.

Trinciatrice professionale multiuso da applicare a trattori con potenza compresa tra 85 e 180 HP. Adatta a lavorare sia posteriormente che lateralmente al trattore. E' consigliata per erba, residui vegetali, ce-spugli e sarmenti fino a  $\varnothing$  7 cm., Ideale per la pulizia di parchi, aree verdi, giardini, bordi di strade, su fossati, argini e terreni inclinati in genere

Broyeur professionnel renforcé multifonctions pour broyer l'herbe, les déchets végétaux, les buissons et les sarments allant de  $\varnothing$  7 cm; adapté pour tracteurs de 85 à 180 CV. Machine idéale pour les personnes qui travaillent pour le compte de tiers et qui doivent nettoyer le rebord des routes, fossés, digues et espaces verts publiques.

Heavy-duty offset / in-line mulcher for grass, residue of vegetables, bushes and pruning up to  $\varnothing$  7 cm., suited for tractors from 85 to 180 HP. Ideal machine for contractors who need to clear slopes, ditches, banks of watercourses, road side banks and public green areas in general.

Desbrozadora de uso profesional indicada para la trituración de hierba, residuos vege-tales, arbustos y restos de poda (hasta 7 cm  $\varnothing$ ), para tractores de 85 a 180 C.V. Ideal para parques, áreas verdes, jardines, cune-tas y terrenos en pendiente en general.

Universalgerät für Heckanbau, für seitliches Mulchen oder hinter dem Schlepper für Gras, Vegetation, Reisig und Äste mit  $\varnothing$  7 cm. für Randstreifen, für Wassergräben und für Böschungen für Traktoren von 85 bis 180 PS.

*Il trattore deve essere dotato di almeno n.2 prese d'olio a doppio effetto / The tractor has to be equipped with n. 2 double effect oil plugs / Der Traktor muss mit 2 doppelwirkenden Hydraulikanschlüssen ausgestattet sein / Le tracteur doit être équipé avec au moins 2 prises d'huile à double effet / El tractor deberá estar equipado con al menos dos enchufes hidráulicos con válvula de doble efecto.*

Mod.													
	cm	Min HP	Max HP	n°	n°	n°	PTO	A cm	B cm	C cm	D cm	E cm	Kg
TA/PS 160	160	85	180	14	42	5	540	160	180	25	270	145	910
TA/PS 180	180	90	180	16	48	5	540	180	180	25	290	165	1010
TA/PS 200	200	100	180	18	54	5	540	200	180	25	310	185	1050
TA/PS 220	220	100	180	20	60	5	540	220	180	25	330	205	1110
TA/PS 250	250	100	180	22	66	5	540	250	180	25	360	235	1220

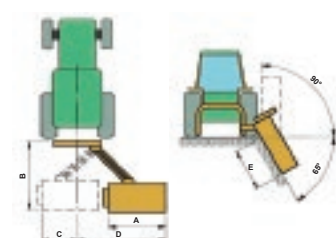

\* Il peso è riferito alla macchina standard (senza accessori) • The weight refers to the machine with standard equipment (without accessories) • Die Gewichtsangabe bezieht sich auf die Maschine in Grundausstattung (ohne Sonderausstattung) • Le poids se réfère à la machine standard (sans accessoires) • El peso se refiere al estándar de la máquina (sin accesorios).





- Sistema flottante con limitatore.
- Floating device, with limiter.
- Schwimmstellung-System mit Hubbegrenzer.
- Système flottante avec limiteur.
- Sistema de enganche flotante con limitador.



- Rullo autopulente regolabile in altezza.
- Self-cleaning and height adjustable roller.
- Selbstreinigender und höhenverstellbarer Stützwalze.
- Rouleau auto-nettoyant réglable en hauteur.
- Rodillo auto-limpiable regulable en altura.

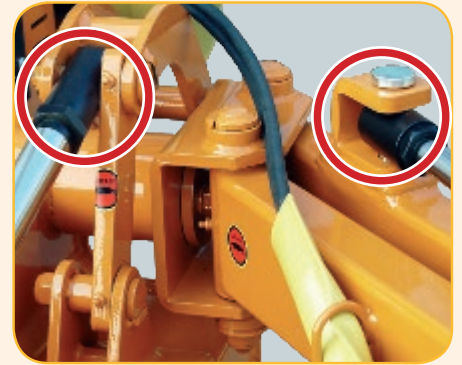

- Martinetti regolabili.
- Adjustable cylinders.
- Einstellbare hydr. Zylinder.
- Vérins réglables.
- Cilindros hidráulicos con extensión ajustable.

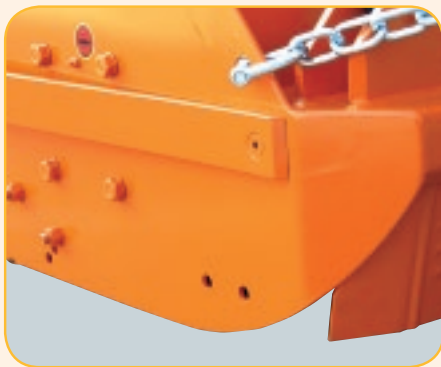

- Fiancata destra arrotondata.
- Chamfered profile on the right-end chassis corner.
- Seitlich Abschrägung auf Mulcherrahmen.
- Coin côté droite arrondi.
- Perfil rebajado en la parte derecha.



- Albero cardanico rinforzato.
- Hardened PTO drive shaft.
- Verstärkte Gelenkwelle.
- Cardan à profil renforcé.
- Eje de TDF reforzado.



Optional

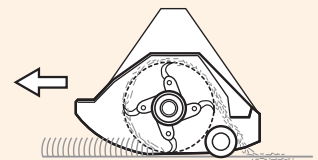

## OPTIONALS



- Sistema antishock BERTI\*.
- Exclusive BERTI Anti-Shock Device\*.
- Anti-Schock System BERTI\*.
- Système antichoc exclusif BERTI\*.
- Dispositivo antichoque exclusivo de Berti\*.



- Slitte d'appoggio antiusura.
- Skids of anti-wearing steel.
- Satz Kufen mit Anti-Verschleißmaterial.
- Jeu patins anti-usure.
- Patines de acero reforzado anti-desgaste.



- Albero cardanico doppio omocinetico.
- Double Wide-Angle drive shaft.
- Doppel-Weitwinkel Gelenkwelle.
- Cardan double homocinétique.
- Cardan doble homocinético.

# TA/PF

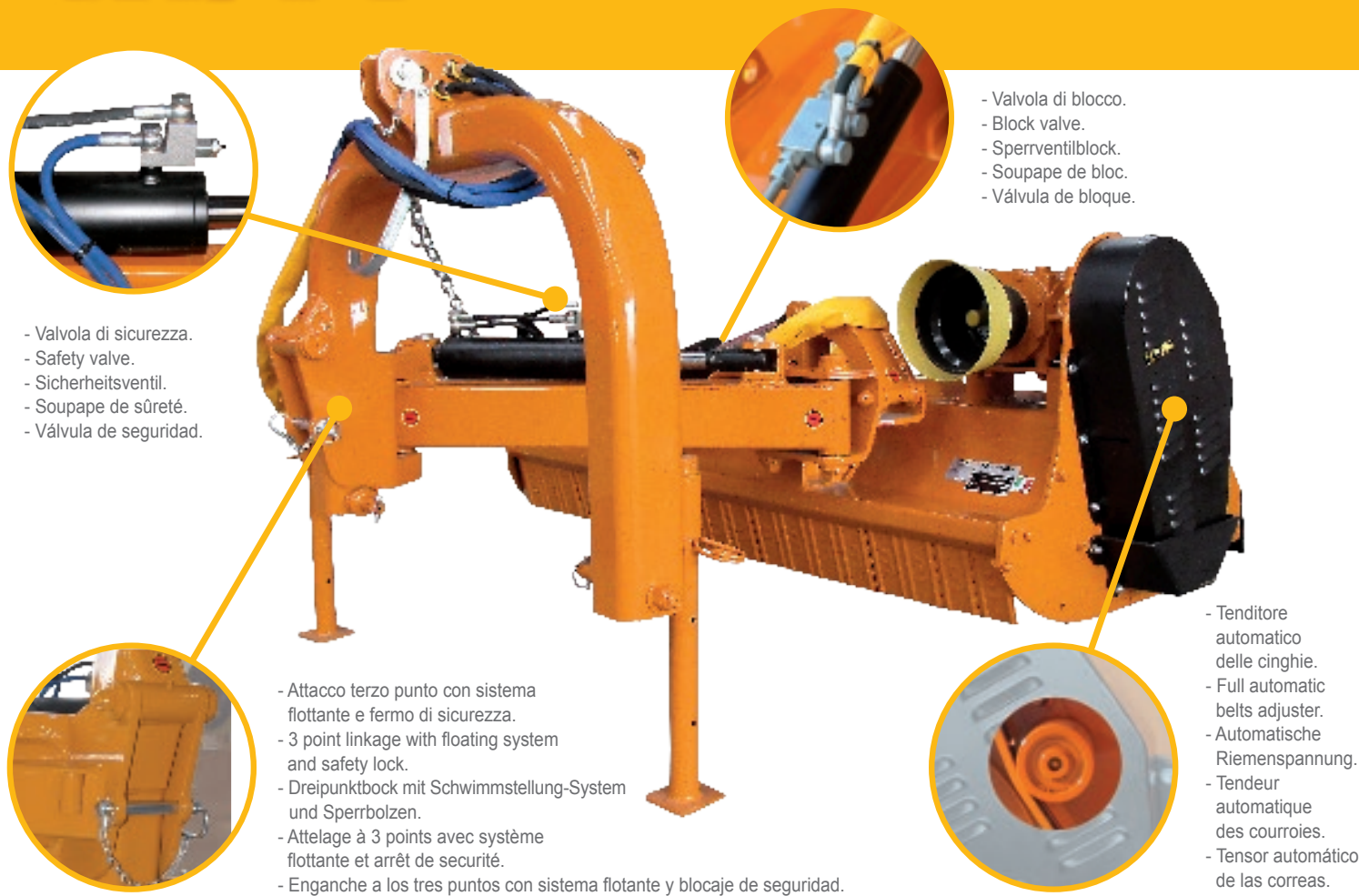



- Valvola di sicurezza.
- Safety valve.
- Sicherheitsventil.
- Soupape de sûreté.
- Válvula de seguridad.

- Valvola di blocco.
- Block valve.
- Sperrventilblock.
- Soupape de bloc.
- Válvula de bloque.

- Attacco terzo punto con sistema flottante e fermo di sicurezza.
- 3 point linkage with floating system and safety lock.
- Dreipunktbock mit Schwimmstellung-System und Sperrbolzen.
- Attelage à 3 points avec système flottante et arrêt de sécurité.
- Enganche a los tres puntos con sistema flotante y bloqueo de seguridad.

- Tenditore automatico delle cinghie.
- Full automatic belts adjuster.
- Automatische Riemenspannung.
- Tendeur automatique des courroies.
- Tensor automático de las correas.

 Trinciatrice professionale multiuso da applicare a trattori con potenza compresa tra 85 e 180 HP. Adatta a lavorare sia posteriormente che lateralmente al trattore. E' consigliata per erba, residui vegetali, cespugli e sarmenti fino a  $\varnothing$  8 cm., Ideale per la pulizia di parchi, aree verdi, giardini, bordi di strade, su fossati, argini e terreni inclinati in genere.







 Broyeur professionnel renforcé multifonctions pour broyer l'herbe, les buissons et les sarments allant jusqu'à  $\varnothing$  8 cm, pour tracteurs de 85 à 180 CV. Machine idéale pour les fermiers et pour les personnes travaillant pour le compte de tiers et qui doivent nettoyer les vergers, les digues, le rebord des routes, les fossés et les terrains inclinés.

 Heavy-duty offset / in-line mulcher for grass, bushes and branches up to  $\varnothing$  8 cm., suited for tractors from 85 to 180 HP. Ideal machine for farmers and contractors who need to clear orchards, slopes, ditches, banks of watercourses.

 Desbrozadora de uso profesional indicada para la trituración de hierba, residuos vege-tales, arbustos y restos de poda (hasta 8 cm  $\varnothing$ ), para tractores de 85 a 180 C.V. Ideal para parques, áreas verdes, jardines, cune-tas y terrenos en pendiente en general.

 Universalgerät für Heckanbau, für seitliches Mulchen oder hinter dem Schlepper für Gras, Vegetation, Reisig und Äste bis  $\varnothing$  8 cm. für Randstreifen, Wassergräben, für Böschungen, und Obstgärten für Traktoren von 85 bis 180 PS.

*Il trattore deve essere dotato di almeno n.2 prese d'olio a doppio effetto / The tractor has to be equipped with n. 2 double effect oil plugs / Der Traktor muss mit 2 doppelwirkenden Hydraulikanschlüssen ausgestattet sein / Le tracteur doit être équipé avec au moins 2 prises d'huile à double effet / El tractor deberá estar equipado con al menos dos enchufes hidráulicos con válvula de doble efecto.*

Mod.													
	cm	Min	Max	n°	n°	n°	PTO	A	B	C	D	E	Kg
<b>TA/PF 160</b>	160	85	180	14	42	5	540	160	180	60	235	130	980
<b>TA/PF 180</b>	180	85	180	16	48	5	540	180	180	60	255	150	1080
<b>TA/PF 200</b>	200	90	180	18	54	5	540	200	180	60	275	170	1120
<b>TA/PF 220</b>	220	90	180	20	60	5	540	220	180	60	295	190	1170
<b>TA/PF 250</b>	250	100	180	22	66	5	540	250	180	60	325	220	1280

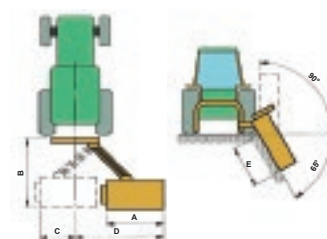

\* Il peso è riferito alla macchina standard (senza accessori) • The weight refers to the machine with standard equipment (without accessories) • Die Gewichtsangabe bezieht sich auf die Maschine in Grundausstattung (ohne Sonderausstattung) • Le poids se réfère à la machine standard (sans accessoires) • El peso se refiere al estándar de la máquina (sin accesorios).





- Sistema flottante con limitatore.
- Floating device, with limiter.
- Schwimmstellung-System mit Hubbegrenzer.
- Système flottante avec limiteur.
- Sistema de enganche flotante con limitador.

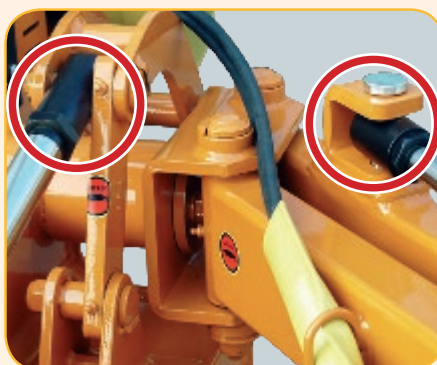

- Martinetti registrabili.
- Adjustable cylinders.
- Einstellbare hydr. Zylindern.
- Vérins réglables.
- Cilindros hidráulicos con extensión ajustable.



- Rullo livellatore regolabile con pulirullo e rastrelli raccoglitori.
- Adjustable and levelling roller, with scraper and rakes.
- Einstellbare Stützwalze mit Abstreifer und Sammelrechen.
- Rouleau palpeur réglable avec décrotoir et râteliers ramasseurs.
- Rodillo nivelador con rascador y rastrillos recogedores.



- Fiancata destra arrotondata.
- Chamfered profile on the right-end chassis corner.
- Seitlich Abschrägung auf Mulcherrahmen.
- Coin côté droite arrondi.
- Perfil rebajado en la parte derecha.



- Albero cardanico rinforzato.
- Hardened PTO drive shaft.
- Verstärkte Gelenkwelle.
- Cardan à profil renforcé.
- Eje de TDF reforzado.



Optional

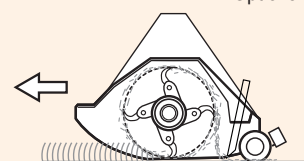

## OPTIONALS



- Sistema antishock BERTI\*.
- Exclusive BERTI Anti-Shock Device\*.
- Anti-Schock System BERTI\*.
- Système antichoc exclusif BERTI\*.
- Dispositivo antichoque exclusivo de Berti\*.



- Slitte d'appoggio antiusura.
- Skids of anti-wearing steel.
- Satz Kufen mit Anti-Verschleißmaterial.
- Jeu patins anti-usure.
- Patines de acero reforzado anti-desgaste.



- Albero cardanico doppio omocinetico.
- Double Wide-Angle drive shaft.
- Doppel-Weitwinkel Gelenkwelle.
- Cardan double homocinétique.
- Cardan doble homocinético.

# WING





- Moltiplicatore rinforzato per trasmissione primaria.
- High-rate overgear for master transmission.
- Verstärktes Übersetzungsgetriebe für Haupt-Antrieb.
- Boîtier renforcé pour transmission primaire.
- Multiplicador reforzado para la transmisión primaria.

- Inclinazione idraulica della testata (+100°/-60°).
- Tilt capacity (+100°/-60°).
- Schwenkbarkeit (+100°/-60°).
- Inclinaison hydraulique de la tête de broyage (+100°/-60°).
- Inclinación hidráulica del cabezal (+100° / -60°).





- Sistema antishock BERTI.
- Exclusive BERTI Anti-Shock Device.
- Anti-Schock System BERTI.
- Système antichoc exclusif BERTI.
- Dispositivo antichoque exclusivo de BERTI.









 Trinciatrice professionale laterale da applicare a trattori con potenza compresa tra 90 e 200 HP. E' consigliata per erba, residui vegetali, cespugli e sarmenti fino a  $\varnothing$  7 cm., ideale per la pulizia di bordi di strade, su fossati, argini e terreni inclinati in genere.

 Broyeur professionnel renforcé multifonctions pour broyer l'herbe, les buissons et les sarments allant jusqu'à  $\varnothing$  7 cm, pour tracteurs de 90 à 200 CV. Machine idéale pour les fermiers et pour les personnes travaillant pour le compte de tiers et qui doivent nettoyer les vergers, les digues, le rebord des routes, les fossés et les terrains inclinés.

 Heavy-Duty offset mltipurpose mulcher, suited for professional operators, to fit tractors from 90 to 200 HP. The machine can mulch grass, brush, heavy vegetation and branches up to  $\varnothing$  7 cm, on tough applications such as road-side, slopes, ditches, watercourses, open fields, etc.

 Desbrozadora de uso profesional indicada para la trituración de hierba, residuos vegetales, arbustos y restos de poda (hasta 7 cm  $\varnothing$ ), para tractores de 90 a 200 C.V. Ideal para parques, áreas verdes, jardines, cunetas y terrenos en pendiente en general.

 Seitlich Mulcher mit Vielzweckanwendung, geeignet für den professionellen Einsatz, für den Anbau an Traktoren mit einer Leistung von 90 bis 200 PS. Das Gerät eignet sich zum Mulchen von Gras, Sträucher wie auch Astwerk bis  $\varnothing$  7 cm, in schwierigen Lagen wie Straßendämmen, Kanalschultern, Gräben usw.

Mod.													
	cm	Min Max	n°	n°	n°	ton.	PTO	A cm	B cm	C cm	D cm	E cm	ca.(*) Kg
<b>WING 180</b>	180	90 150	16	48	5+5	4,0	1000	180	270-340	90-160	70	78	1390
<b>WING 200</b>	200	90 150	18	54	5+5	4,0	1000	200	290-360	90-160	70	78	1430
<b>WING 220</b>	220	100 170	20	60	5+5	4,5	1000	220	310-380	90-160	70	78	1480
<b>WING 250</b>	250	100 200	22	66	5+5	5,0	1000	250	340-410	90-160	70	78	1510

\* Il peso è riferito alla macchina standard (senza accessori) • The weight refers to the machine with standard equipment (without accessories) • Die Gewichtsangabe bezieht sich auf die Maschine in Grundausstattung (ohne Sonderausstattung) • Le poids se réfère à la machine standard (sans accessoires) • El peso se refiere al estándar de la máquina (sin accesorios).





- Tenditore automatico delle cinghie.
- Automatic belts adjuster.
- Automatische Riemenspannung.
- Tendeur automatique des courroies.
- Tensor automático de las correas.



- Regolazione idraulica altezza corpo macchina.
- Hydraulic height adjusting.
- Hydr. Höhenverschiebung.
- Réglage hydraulique de l'hauteur.
- Ajuste hidráulico de la altura.



- Sistema flottante con limitatore.
- Floating device, with limiter.
- Schwimmstellung-System mit Hubbegrenzer.
- Système flottante avec limiteur.
- Sistema de enganche flotante con limitador.



- Trasmissione primaria a cinghie.
- Master transmission through V-belts.
- Haupt-Antrieb durch gezähnte Keilriemen.
- Transmission primaire par courroies.
- Transmisión primaria por correas en "V".



- Trasmissione secondaria a cinghie con scatola ingranaggi con ruota libera rinforzata.
- Secondary transmission through V-belts and free wheel in the gearbox.
- Keilriemenantrieb zum Mulcherrotor und Freilauf im Getriebe.
- Transmission secondaire par courroies avec boîtier avec roue libre renforcé.
- Transmisión secundaria por correas en "V" y rueda libre en la caja de transmisión.



- Rullo autopulente regolabile in altezza.
- Self-cleaning and height adjustable roller.
- Selbstreinigender und höhenverstellbarer Stützwalze.
- Rouleau auto-nettoyant réglable en hauteur.
- Rodillo auto-limpiable regulable en altura.

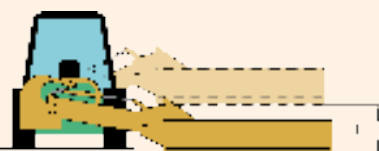
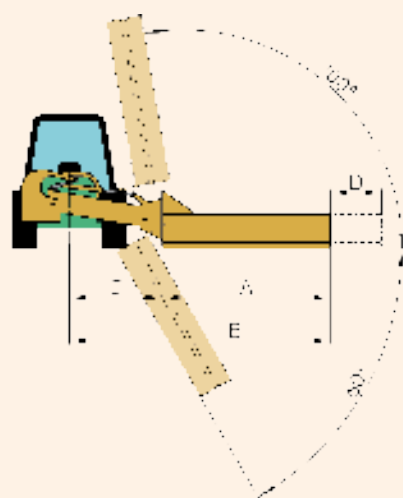

### OPTIONALS



- Albero cardanico.
- Pto drive shaft.
- Gelenkwelle.
- Arbre cardan.
- Cardan.



Optional

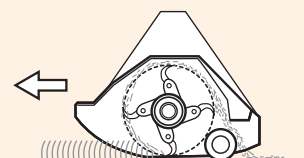



TA/MI



TA/M





TA



TA/S





TA/P



TA/PS





**TA/PF**



**WING**



**\*ANTI-SHOCK BERTI**

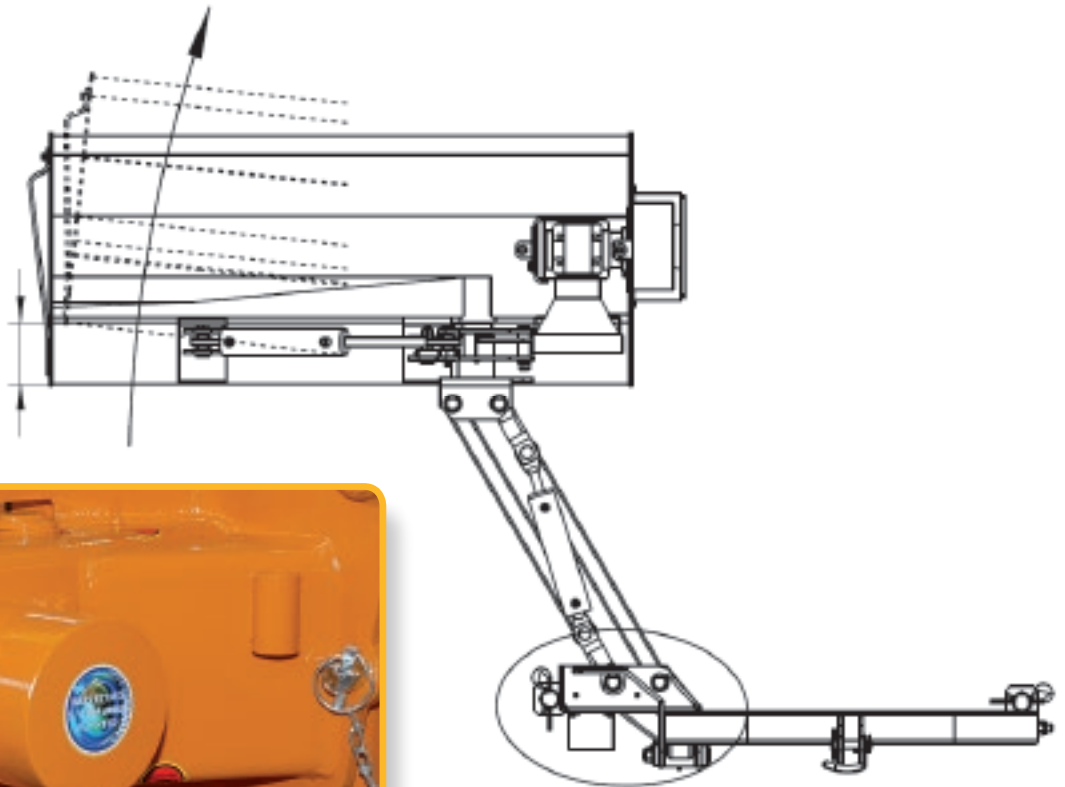



www.bertima.it

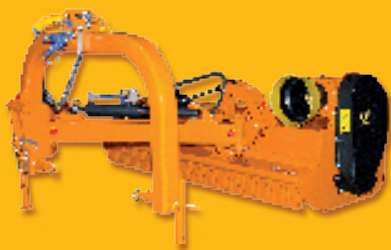

TA/MI

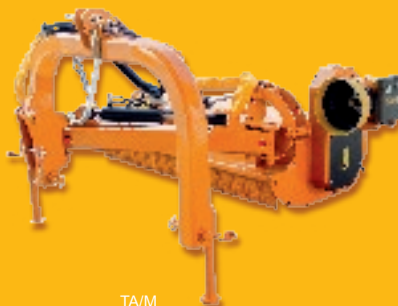

TA/M

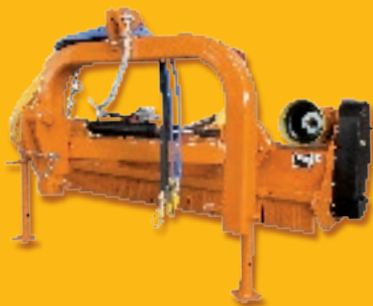

TA

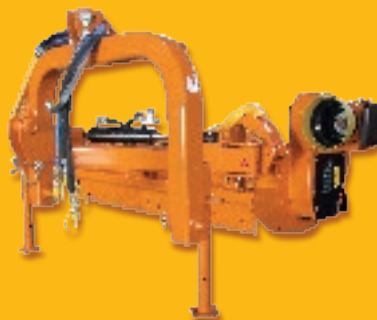

TA/S



TA/P

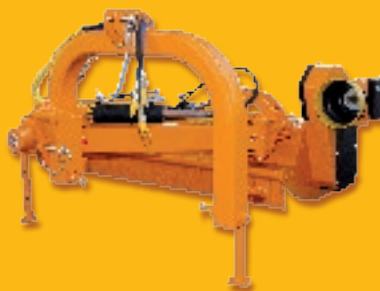

TA/PS



TA/PF



WING

Le illustrazioni e i dati del presente catalogo sono indicative e non vincolanti per il costruttore • All pictures and data above are indicative only and not binding for the manufacturer • Alle in diesem Katalog enthaltenen Angaben und Zeichnungen sind annähernd und unverbindlich • Toutes les données insérées dans ce catalogue ont été indiquées seulement à titre de renseignement • Las fotografías y los datos mostrados son meramente indicativos y podrán ser variados sin previo aviso por el fabricante.



**BERLINI**  
MACCHINE AGRICOLE



Via Musi, 1/A-3 - 37042 Caldiero (VR) ITALY  
Tel. +39.045.6139711 - Fax +39.045.6150251  
info@bertima.it



MADE IN ITALY